

ASSEMBLY INSTRUCTIONS:

Product Code : DIA-CB18

Product Name: Diamond Cupboard

TIME REQUIRED:

40 minutes

TOOLS REQUIRED:

Screwdriver, Electric Drill, Pencil, Measuring tape/Ruler

*Tools are not included.

SKILL REQUIRED:

Easy  Hard

The Assembly Skill Rating is a 5-point system that shows the degree of effort needed in assembling a specific product. With 1 being easy for the average person and 5 requiring an expert. For most products, two persons are recommended.

NOTE

- As this is a commercial product, some intermediate skills may be required.
 - No pre-drill holes or markings are provided on our table or desk tops.
 - Please check you have all hardware before assembling.
- If you are missing any hardware, please contact your Rapidline reseller. Please ensure you have the name of the item, required hardware part and quantity.
 - Please retain your receipt as proof of purchase to validate your warranty.
- Assemble on a clean, flat, smooth surface such as a rug or carpet to avoid parts from being scratched.
 - Remove all wrapping materials, including staples and packing straps before you start to assemble
 - Keep all hardware parts out of reach of children.

CAUTION

- Heavy product. Do not attempt to lift or move without help
- Do not tighten screws and bolts until completely assembled.
- Do not use this product unless all bolts and screws are firmly secured and tightened.

WARNING

- If parts are missing, broken, damaged or worn stop using the product until all repairs are made.
 - Failure to follow these warnings could result in serious injury.

ASSEMBLY INSTRUCTIONS

rapidline
FURNITURE FOR TODAY

DIA-CB18

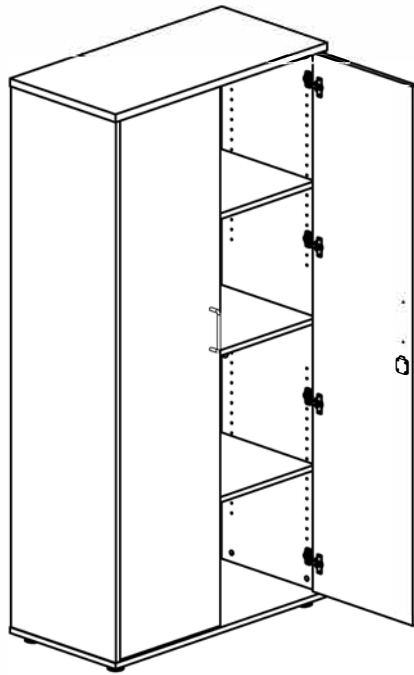

pin 6x35 1 25PCS	CAM 2 25PCS
Cam Cover 3 25PCS	Bolt Minifix 4 8PCS
Hinge&Mount Plate 5 8PCS	T-Handle 6 2PCS
Screw 4x22 7 4PCS	Screw 4x16 8 32PCS
Screw 4x30 9 4PCS	CUSHIOA 26Hx62 10 4PCS
LOCK 11 1PCS	Screw 4x20 12 4PCS
Screw 3.5x13 13 2PCS	

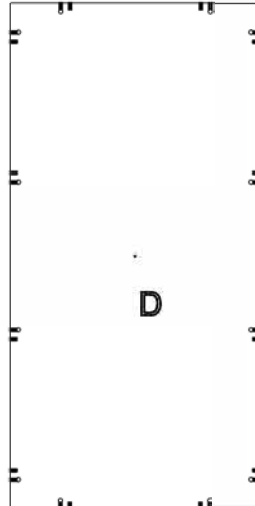
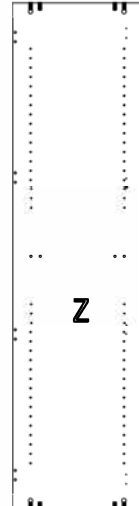
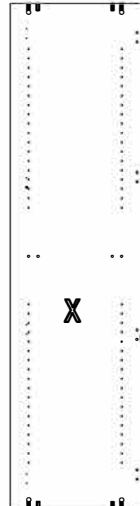
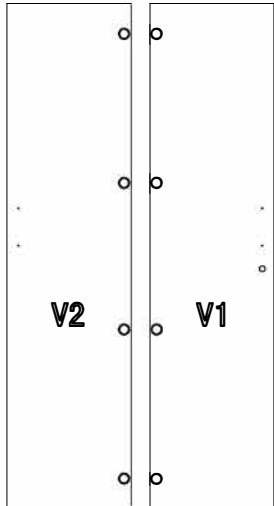
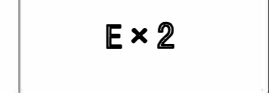
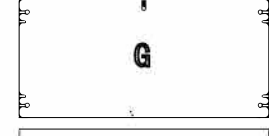
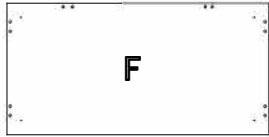
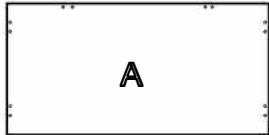

2

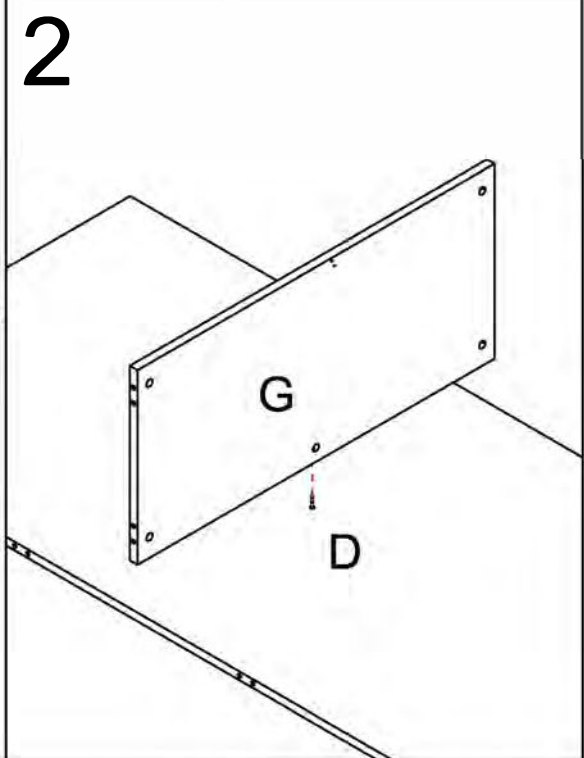
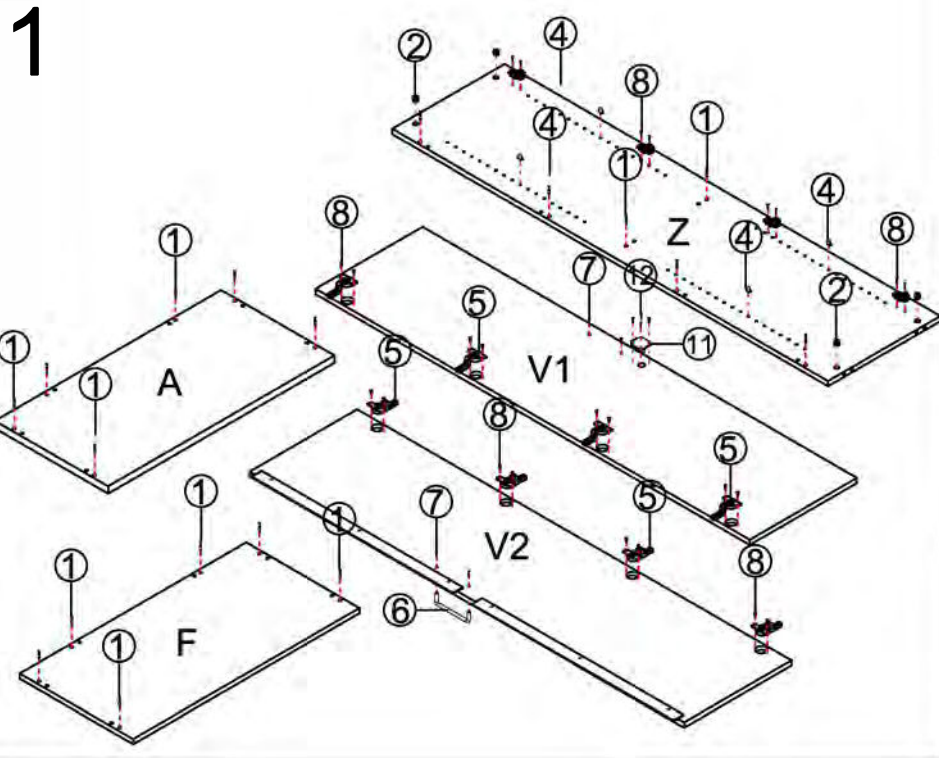

3

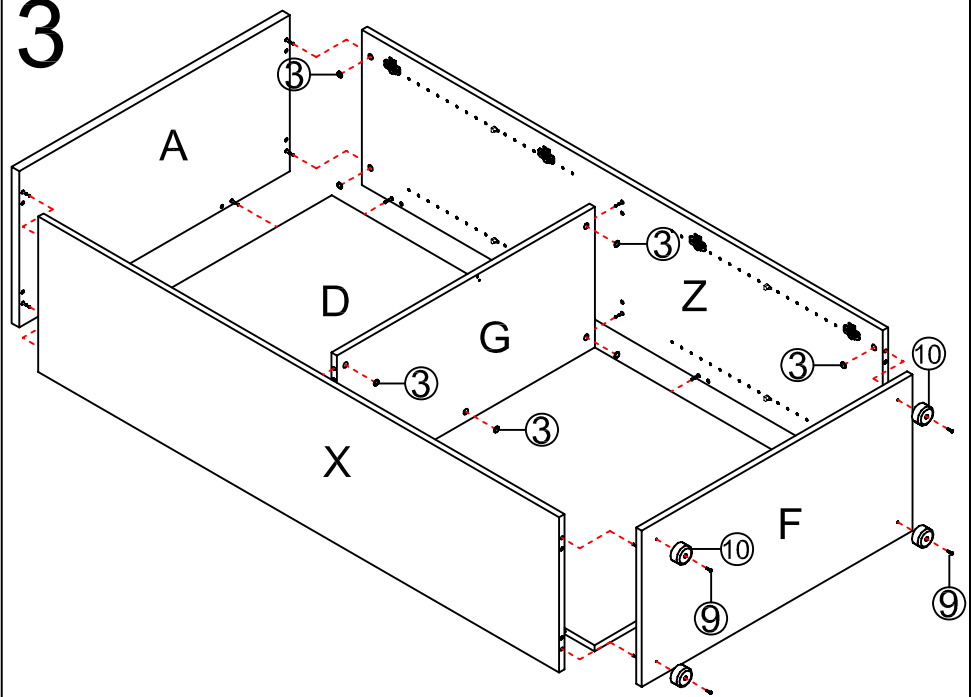

4

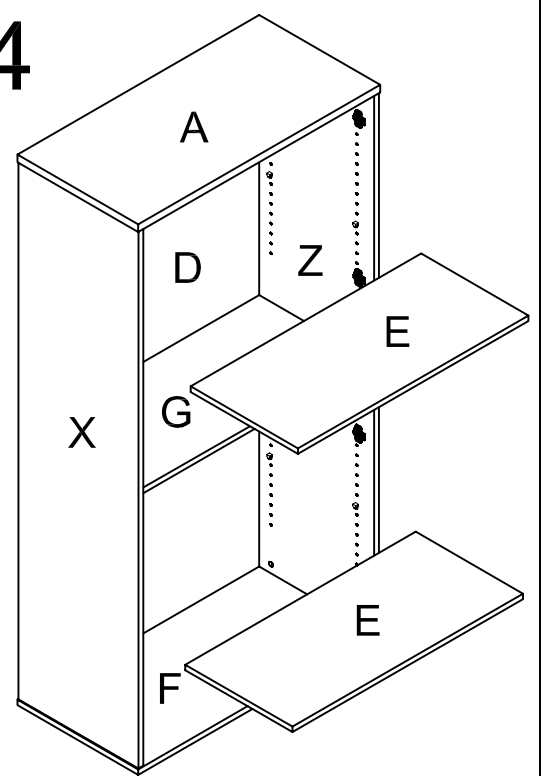

5

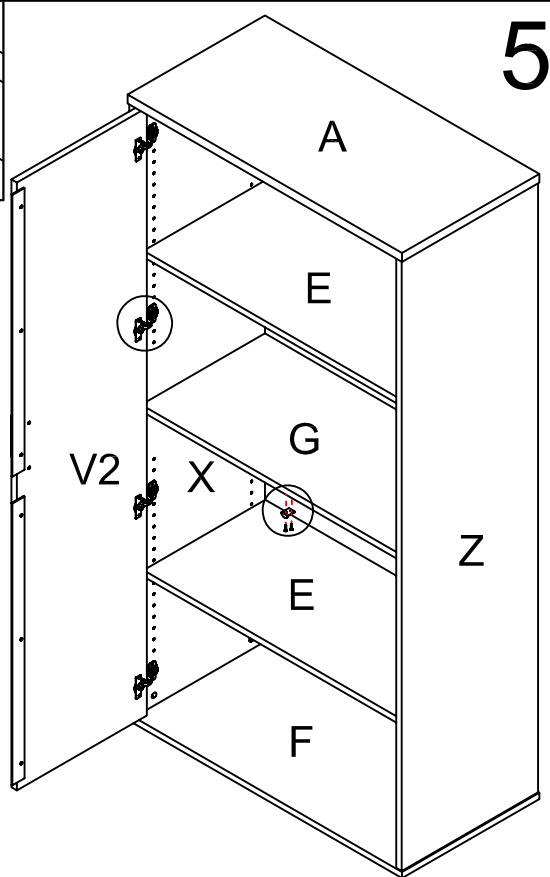

6

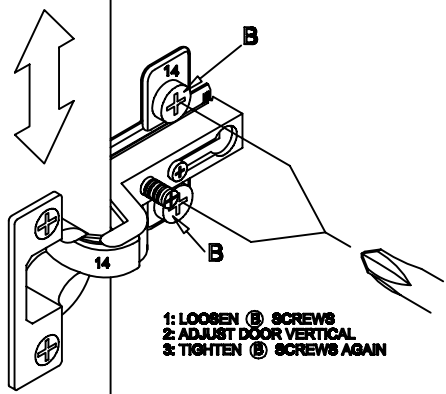
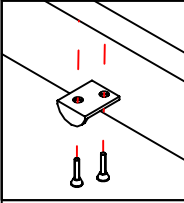
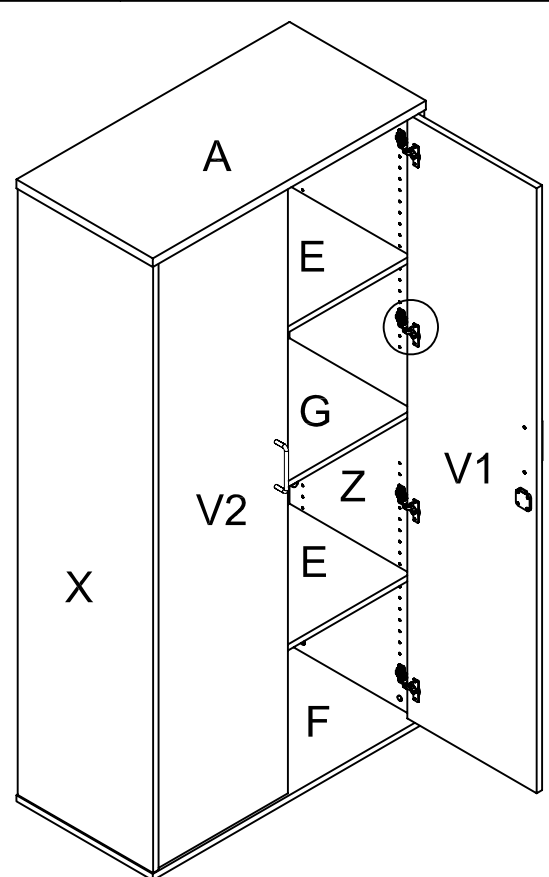

1: LOOSEN SCREW B
 2: ADJUST DOOR VERTICAL
 3: TIGHTEN SCREW B AGAIN

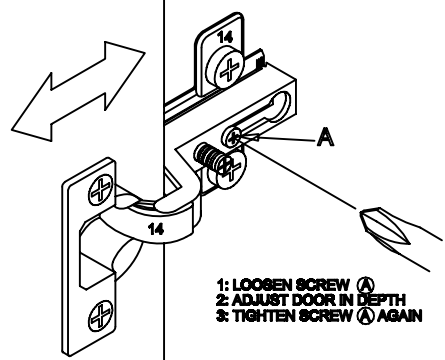

1: LOOSEN SCREW A
 2: ADJUST DOOR IN DEPTH
 3: TIGHTEN SCREW A AGAIN

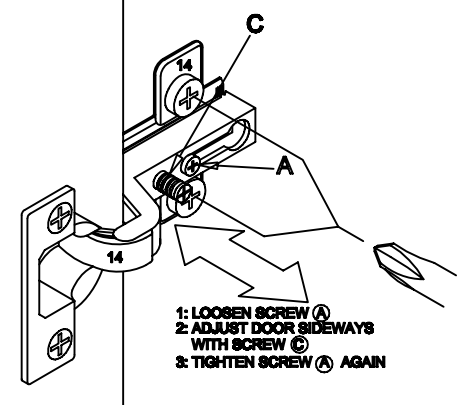

1: LOOSEN SCREW A
 2: ADJUST DOOR SIDWAYS
 WITH SCREW C
 3: TIGHTEN SCREW A AGAIN