

Assembly Instructions

Parts and Tools list

NO.	Name	Qty	NO.	Name	Qty
1	Support Beam	1	11	Rubber Cushion	8
2	Foot	2	12	Plastic Pad	8
3	M6*40 Screw	8	13	ST3.5*19 Screw	2
4	Bracket	2	14	ST4.8*19 Screw	2
5	Lifting System	1set	15	ST4.8*25 Screw	9
6	Driveshaft	1set			
7	4mm Hex Spanner	1			
8	5mm Hex Spanner	1			
9	M6*12 Screw	4			
10	M8*50 Screw	4			

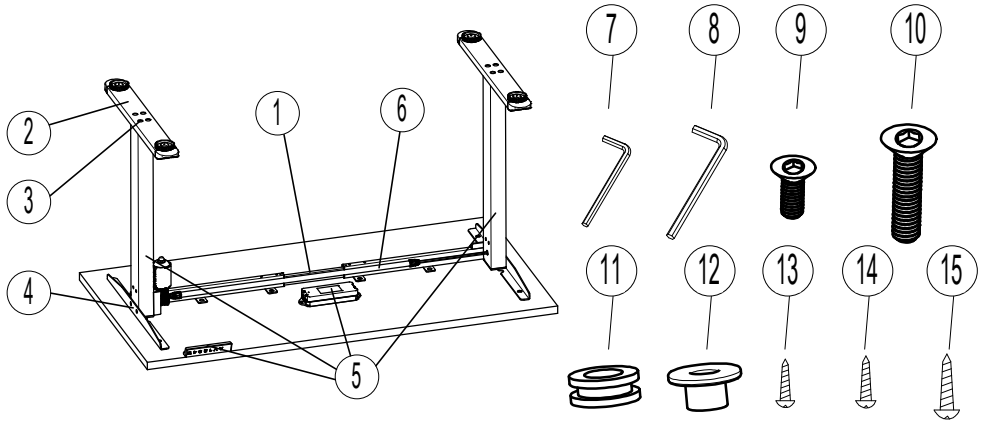

- 1** Loosen the M6*10 screw on the beam with 4mm hexagon wrench, then adjust the length of the beam according to the tops, and finally fix the beam with the screw on the beam.

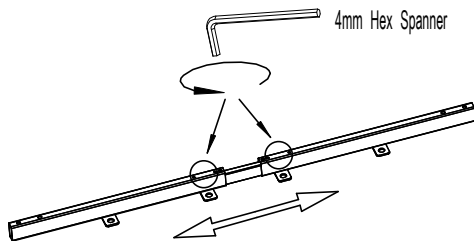

- 2** Attach legs to the beam using 4 of M8*50 screws.

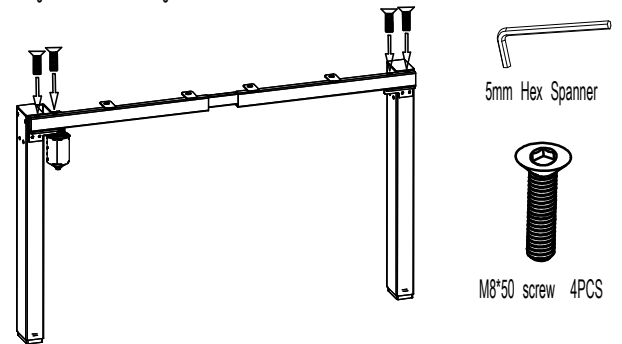

- 3** Attach 2 feet to leg using 8 of M6*40 screws.

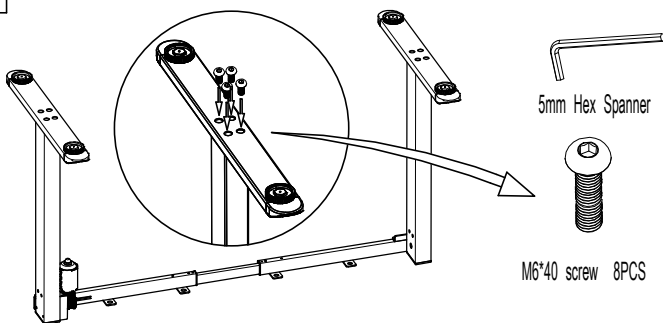

- 4** Attach brackets to beam using 4 of M6*12 screws.

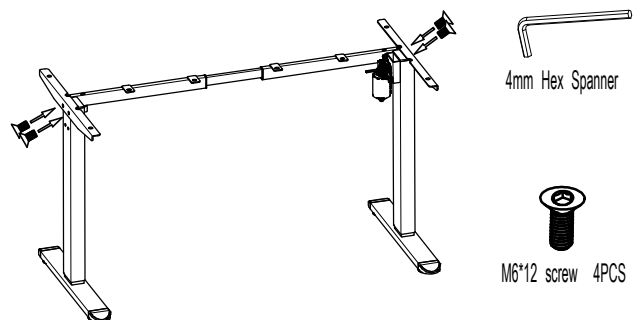

- 5** Fit the rubber cushion and plastic pad to the brackets and beam.

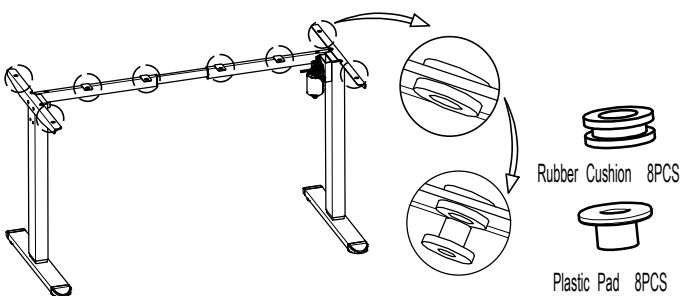

- 6** Loosen nut on each end of the transmission rod by hand, connect the hex rod of main leg to one end of the transmission rod and the hex rod of transmission rod insert to the other leg.

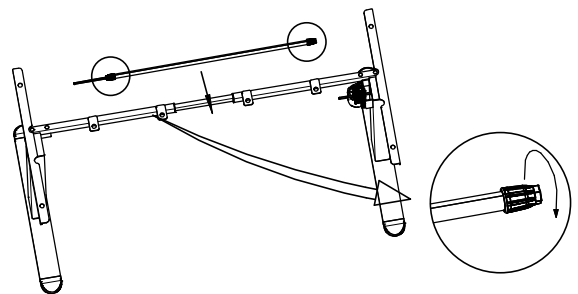

- 7** Fix table top to frames with 8 of ST4.8*25 screws, then fix control boxes to below table top with 2 of ST4.8*19 screws, at last fix handsets to below table top with 2 of ST3.5*19 screws.

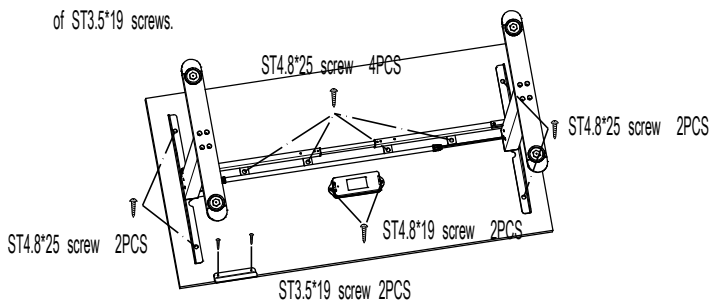

- 8** Connect the control box to the handset and to the motor.

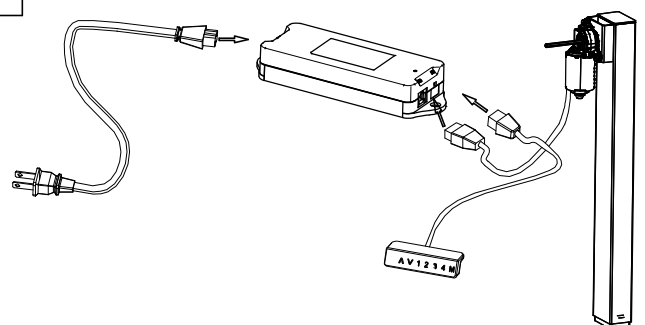

ASCEND ALPHA/OMEGA Handset Operation Manual



1. Handset Interface

- ▶ UP
- ▶ DOWN
- ▶ Setting Button M
- ▶ Height Memory Button 1
- ▶ Height Memory Button 2
- ▶ Height Memory Button 3
- ▶ Height Memory Button 4

2. Initialization Operation

- ▶ When the system is abnormal, or the handset displays "RST", it is necessary to initialize the standing desk. The initialization operation is to press and hold <↓> until the frame has reached the lowest position; Then press and hold <↓> for 5 seconds until you hear a beep.

3. Operation of the Desk

- ▶ Press <↑> to move the desk up until it reaches the highest position.
- ▶ Press <↓> to move the desk down until it reaches the lowest position.
- ▶ Press <↑> or <↓> in short desk runs a small distance.

4. The Memory Function

- ▶ This handset can store n memory points. Move the desk up or down to the desired position; Press <M> in short until the display shows "S-", and "-" flashes, then press <1> to save position 1; Repeat the procedure to save the other positions.

5.Upper and Lower Limit Settings

▶ The system supports the height limit of the desk. The operation method is, press and hold the <↑>&<↓> at the same time for 5 seconds at the corresponding height until hear the buzzer, indicating the limit position is stored successfully. When the desk is in the upper half of the stroke, the limit is the highest position. When in the lower half of the table stroke, the limit is the lowest position.

▶ Cancel height limit

Method 1: Reset the system, the high and low limit will be cancelled.

Method 2: Run the desk to the limit high or low point, press and hold the <↑>&<↓> for 5 seconds at the same time until hear the buzzer, indicating that the limit position is canceled successfully.

6.Lock and Unlock

▶ Lock: Press and hold <M>&<↑> together for 5 seconds, when the digital display shows "Loc", it means the system has been locked, and the desk cannot be raised or lowered.

▶ Unlock: Press and hold <M>&<↓> together for 5 seconds, when the digital display shows from "Loc" to normal digital, it means the system has been unlocked.

7.Reset

▶ When the system is replaced with a new leg, or the parameters need to be restored to the factory settings, press and hold <↑>&<↓> for 10 seconds at the same time to hear a long buzzer, and the parameters are restored to the factory settings and forced to initialize.

8.Timing Setting

▶ Press <1>&<3> at the same time, the handset displays 0.0h during the initial setting, then press <↑>or<↓> to adjust the timing, with 0.5 hours as a change, and automatically exit after 2 seconds. At this time, a decimal point will flash after the handset is turned off, indicating that there is a timing running. When the timing is reached, the buzzer will beep 5 times and the handset will wake up automatically.

9. Internal Parameters

► Long press <M> for 15 seconds, handset display shows "S-x", and "x" flashes ("x" is the parameter group). At this time, press <M> to enter the parameter group to set the corresponding parameters, and press <↑> or <↓> to switch the parameter group. After setting successfully, press <M> to return to the running interface.

The parameters that can be set are as follows:

a、"S-1" CM or INCH

Use <↑> or <↓> to select 1 or 0; (0 = CM & 1 = INCH)

To save, press <S/M> again.

b、"S-2" Adjust anti-collision sensor sensitivity

0: means off, 1: is the least sensitive and 8: is the most sensitive.

10. Error Code

Error Code	Possible Cause	Action
E01	The main supply voltage over 45V.	Check the main power.
E02	Rod height difference between the two legs is more than 1 cm.	Initialize the frame. Reset the operation.
E04	Handset connection or communication error occurred.	Check the power cable of handset.
E05	The sensor encounters an obstacle and stops functioning.	Release the button and restart.
E06	The main power supply failed to start, below 20V.	Change the main power supply, or check the main power supply cable.
E07	Protection when the main power supply is running, below 20V.	Reconnect power. Power on reset.
E08	Frame tilts when running.	Initialize the frame. Reset the operation.

Error Code	Possible Cause	Action
HOT	Temperature of motor is high or running time exceeds 2 mins within 18 mins.	Wait for motor to cool. Let system rest for at least 18 mins.
E11	The Motor 1 is not connected.	Check power cable of motor.
E12	Error in the Motor 1 current sampling channel.	Change the control box.
E13	The Motor 1 is out of phase and has phase line disconnection.	Check the motor to determine whether the phase line connection is abnormal.
E14	The Motor 1 Hall sensor error, or Hall wire disconnected.	Check the Hall signal, or change the power cable of motor.
E15	Short-Circuit inside the Motor 1.	Change the motor.
E16	Locked-Rotor inside the Motor 1.	Initialize the frame. Reset the operation.
E17	The Motor 1 runs in the wrong direction.	Change the motor wire or Hall wire.
E18	Weight on Motor 1 is over the limit.	Reduce the weight by removing items.
E21	The Motor 2 is not connected.	Check power cable of motor.
E22	Error in the Motor 2 current sampling channel.	Change the control box.
E23	The Motor 2 is out of phase and has phase line disconnection.	Check the motor to determine whether the phase line connection is abnormal.
E24	The Motor 2 Hall sensor error, or Hall wire disconnected.	Check the Hall signal, or change the power cable of motor.
E25	Short-Circuit inside the Motor 2.	Change the motor.
E26	Locked-Rotor inside the Motor 2.	Initialize the frame. Reset the operation.
E27	The Motor 2 runs in the wrong direction.	Change the motor wire or Hall wire.
E28	Weight on Motor 2 is over the limit.	Reduce the weight by removing items.
E40	The control box is disconnected in series.	Check the connection wires.
E41	Error in the serial signal.	Check the connection wires, or change the control box.
E42	Eeprom error.	Change the control box.
E43	Error in Anti-Collision Sensor.	Change the control box.