



## ASSEMBLY INSTRUCTIONS:

Product Code : TULSA-BT

Product Name: Tulsa Boardroom Table

### TIME REQUIRED:

25 minutes

### TOOLS REQUIRED:

Screwdriver, Electric Drill, Pencil, Measuring tape/Ruler

\*Tools are not included.

### SKILL REQUIRED:

Easy ●●●○○ Hard

The Assembly Skill Rating is a 5-point system that shows the degree of effort needed in assembling a specific product. With 1 being easy for the average person and 5 requiring an expert. For most products, two persons are recommended.

#### NOTE

- As this is a commercial product, some intermediate skills may be required.
  - No pre-drill holes or markings are provided on our table or desk tops.
    - Please check you have all hardware before assembling.
- If you are missing any hardware, please contact your Danny reseller. Please ensure you have the name of the item, required hardware part and quantity.
  - Please retain your receipt as proof of purchase to validate your warranty.
- Assemble on a clean, flat, smooth surface such as a rug or carpet to avoid parts from being scratched.
  - Remove all wrapping materials, including staples and packing straps before you start to assemble
    - Keep all hardware parts out of reach of children.

#### CAUTION

- Heavy product. Do not attempt to lift or move without help
- Do not tighten screws and bolts until completely assembled.
- Do not use this product unless all bolts and screws are firmly secured and tightened.

#### WARNING

- If parts are missing, broken, damaged or worn stop using the product until all repairs are made.
  - Failure to follow these warnings could result in serious injury.

# ASSEMBLY INSTRUCTIONS

TF189

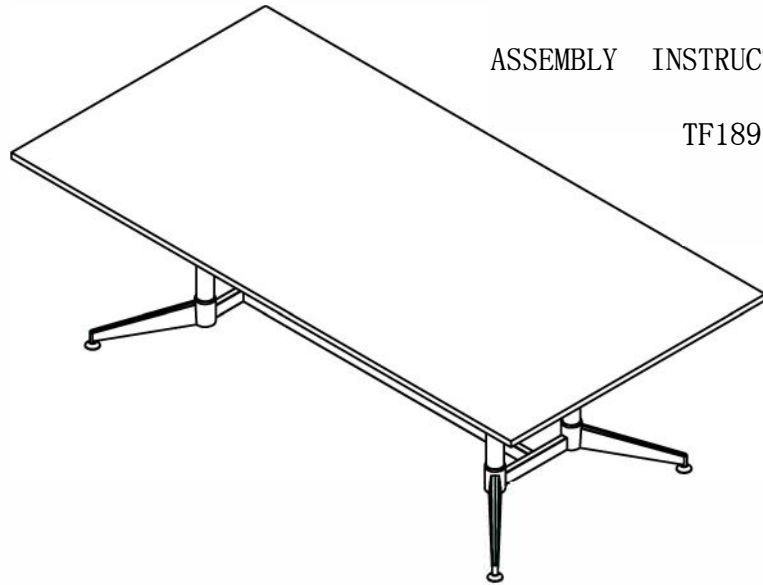

	M8*16H 28pcs
	M5*20H 12pcs
	M12 1pcs
	M6 1pcs
	M6 1pcs
	ø16 1pcs

1

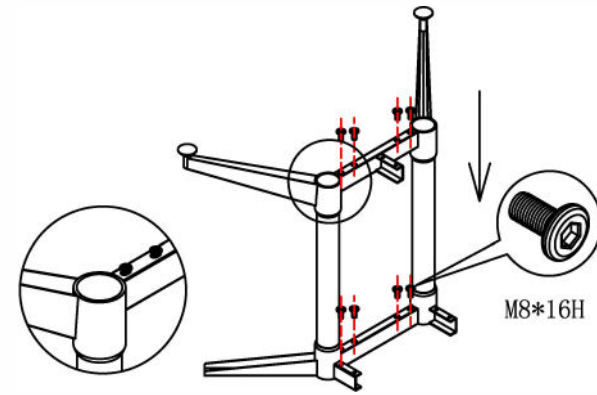

Slide Both The Bottom And Top Cross Bar Into The Left & Right Hand Side End Uprights - Attach Cross Bars With M8 Bolts ( Do Not Completely Tighten Bolts )

2

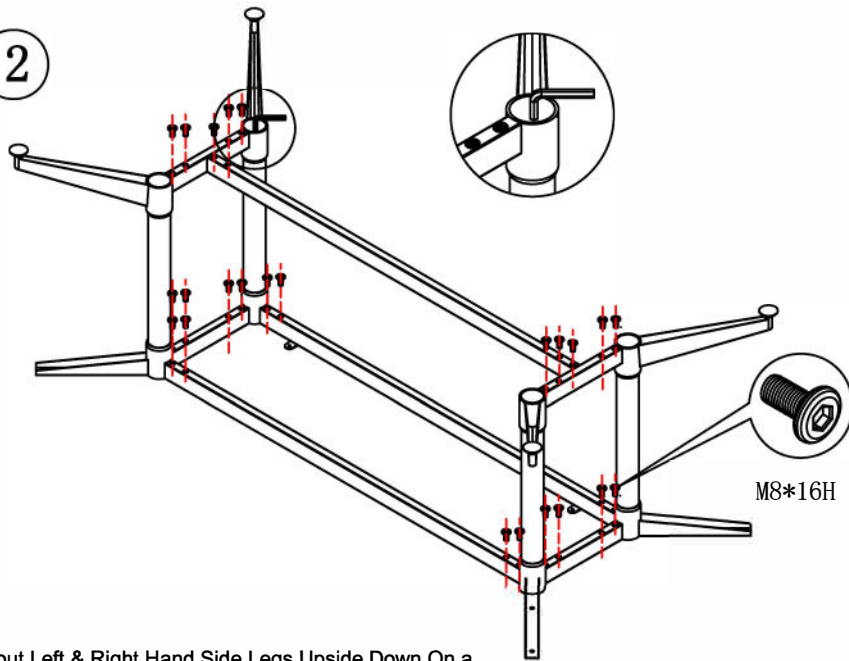

Layout Left & Right Hand Side Legs Upside Down On a Flat Surface. Slide Central Support Beams Into Legs - Attach Support Beams With M8 Bolts ( Do Not Completely Tighten Bolts ) . Once The Frame Is Sitting Flush On the Flat Surface, Tighten All Bolts Completely.

3

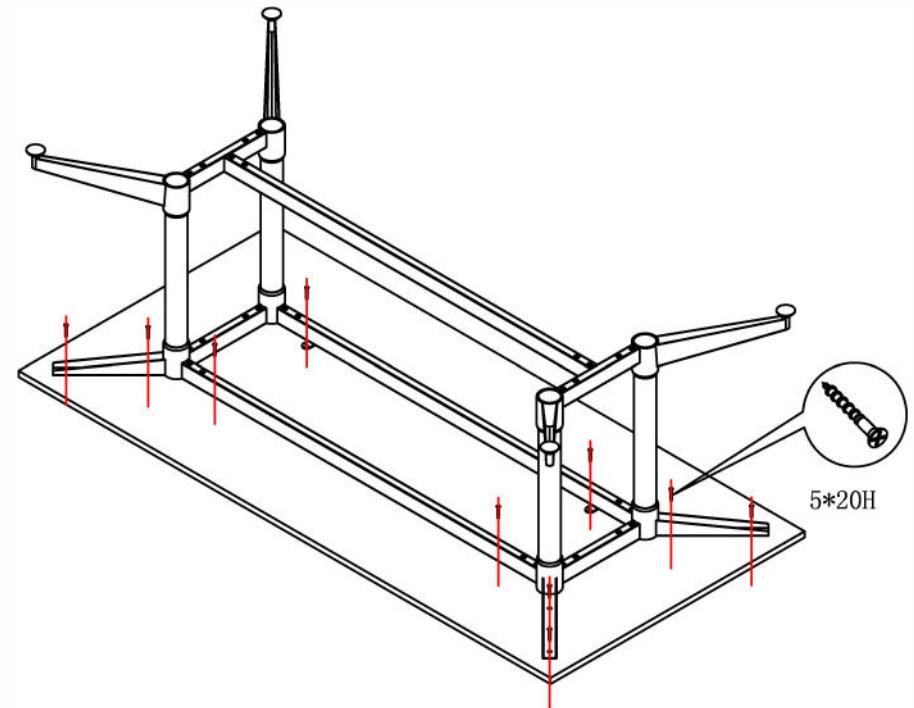





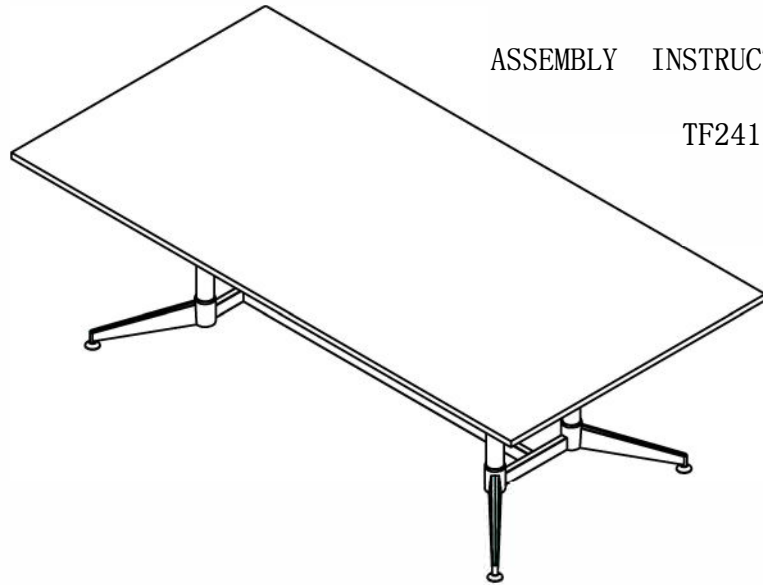

M5\*20H

# ASSEMBLY INSTRUCTIONS

TF2412

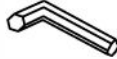

	M8*16H 28pcs
	M5*20H 12pcs
	M12 1pcs
	M6 1pcs
	M6 1pcs
	ø16 1pcs

1

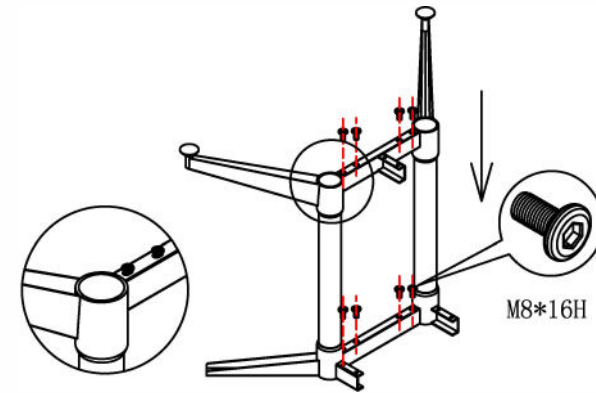

Slide Both The Bottom And Top Cross Bar Into The Left & Right Hand Side End Uprights - Attach Cross Bars With M8 Bolts ( Do Not Completely Tighten Bolts )

2

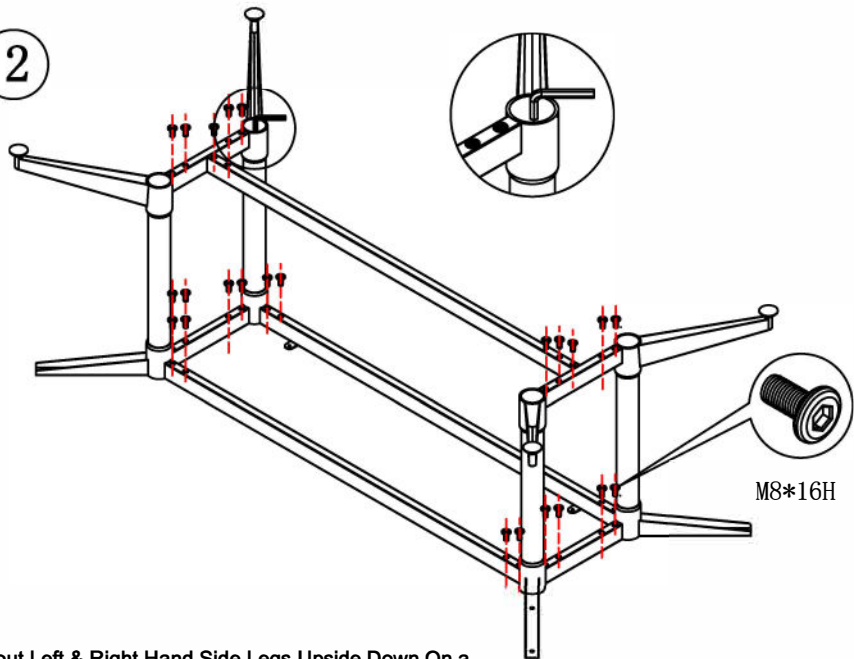

Layout Left & Right Hand Side Legs Upside Down On a Flat Surface. Slide Central Support Beams Into Legs - Attach Support Beams With M8 Bolts ( Do Not Completely Tighten Bolts ) . Once The Frame Is Sitting Flush On the Flat Surface, Tighten All Bolts Completely.



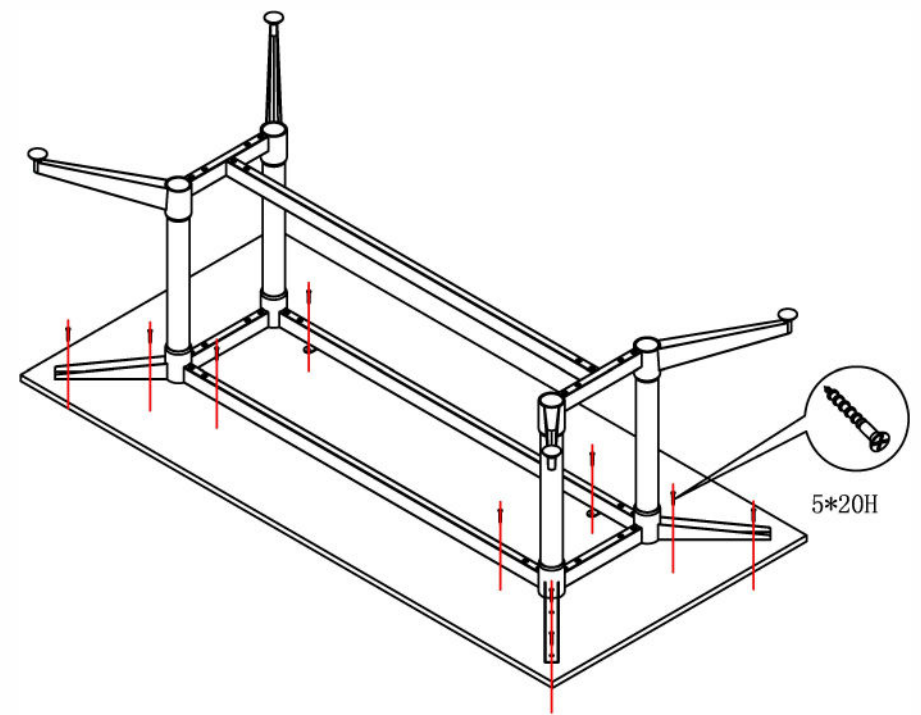



3

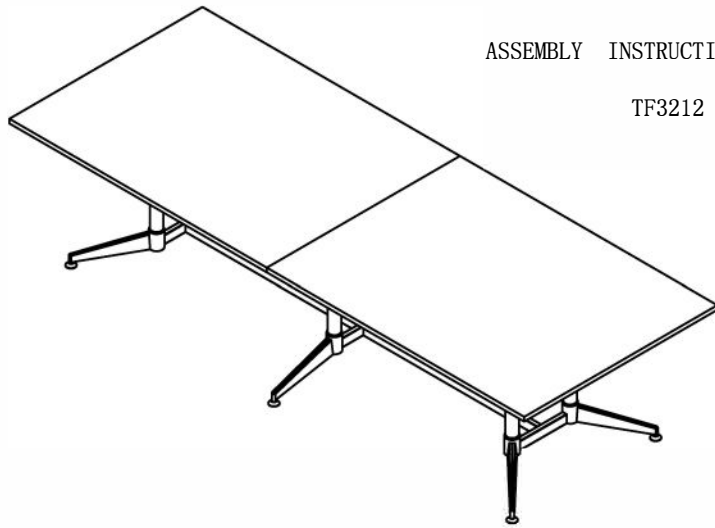

ASSEMBLY INSTRUCTIONS

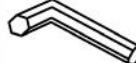
TF3212



	M8*16H 48pcs
	M5*20H 26pcs
	M12 1pcs
	M6 1pcs
	M6 1pcs
	φ16 1pcs

1

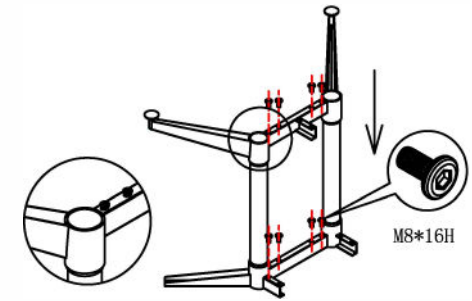

Slide Both The Bottom And Top Cross Bar Into The Left & Right Hand Side End Uprights - Attach Cross Bars With M8 Bolts ( Do Not Completely Tighten Bolts )

2

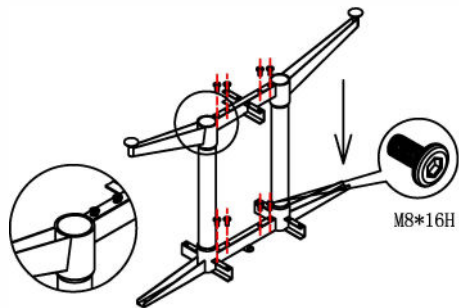

Slide Both The Bottom And Top Cross Bar Into The Central Uprights - Attach Cross Bars With M8 Bolts ( Do Not Completely Tighten Bolts )

3

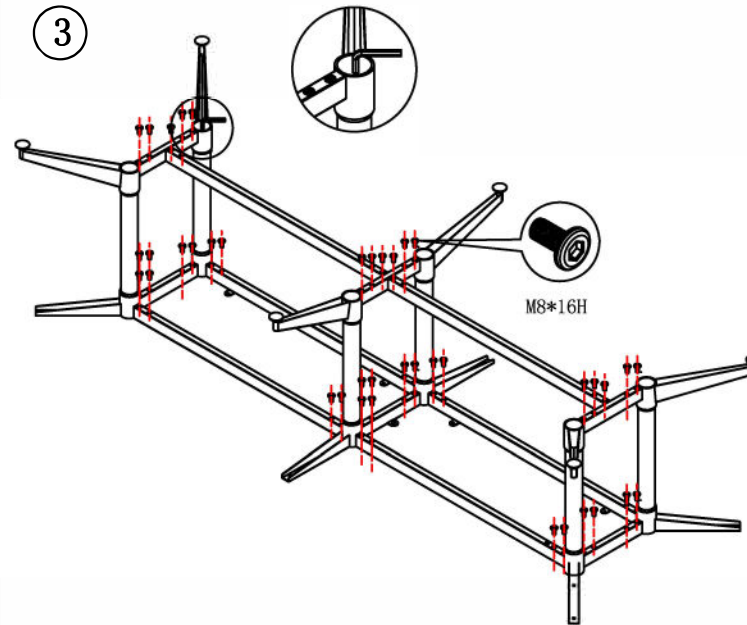

Layout Left, Right and Central Leg Upside Down On a Flat Surface. Slide Central Support Beams Into Legs - Attach Support Beams With M8 Bolts ( Do Not Completely Tighten Bolts ) . Once The Frame Is Sitting Flush On the Flat Surface, Tighten All Bolts Completely.

4

