

ASSEMBLY INSTRUCTIONS:

Product Code : CHIP-ERGO

Product Name: Chip-Ergo Office Chair



TIME REQUIRED:

10 minutes

TOOLS REQUIRED:

Screwdriver, Electric Drill, Pencil, Measuring tape/Ruler

*Tools are not included.

SKILL REQUIRED:

Easy ●●○○○ Hard

The Assembly Skill Rating is a 5-point system that shows the degree of effort needed in assembling a specific product. With 1 being easy for the average person and 5 requiring an expert. For most products, two persons are recommended.

NOTE

- As this is a commercial product, some intermediate skills may be required.
 - No pre-drill holes or markings are provided on our table or desk tops.
 - Please check you have all hardware before assembling.
- If you are missing any hardware, please contact your Danny reseller. Please ensure you have the name of the item, required hardware part and quantity.
 - Please retain your receipt as proof of purchase to validate your warranty.
- Assemble on a clean, flat, smooth surface such as a rug or carpet to avoid parts from being scratched.
- Remove all wrapping materials, including staples and packing straps before you start to assemble
 - Keep all hardware parts out of reach of children.

CAUTION







- Heavy product. Do not attempt to lift or move without help
- Do not tighten screws and bolts until completely assembled.
- Do not use this product unless all bolts and screws are firmly secured and tightened.

WARNING

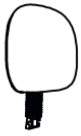
- If parts are missing, broken, damaged or worn stop using the product until all repairs are made.
- Failure to follow these warnings could result in serious injury.

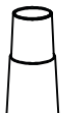

CHIP-ERGO

<p>Back 1</p>  <p>1PC</p>	<p>Seat 2</p>  <p>1PC</p>	<p>Castor 3</p>  <p>5PCS</p>
<p>Gaslift 4</p>  <p>1PC</p>	<p>Set 5</p>  <p>1PC</p>	<p>Star Base 6</p>  <p>1PC</p>

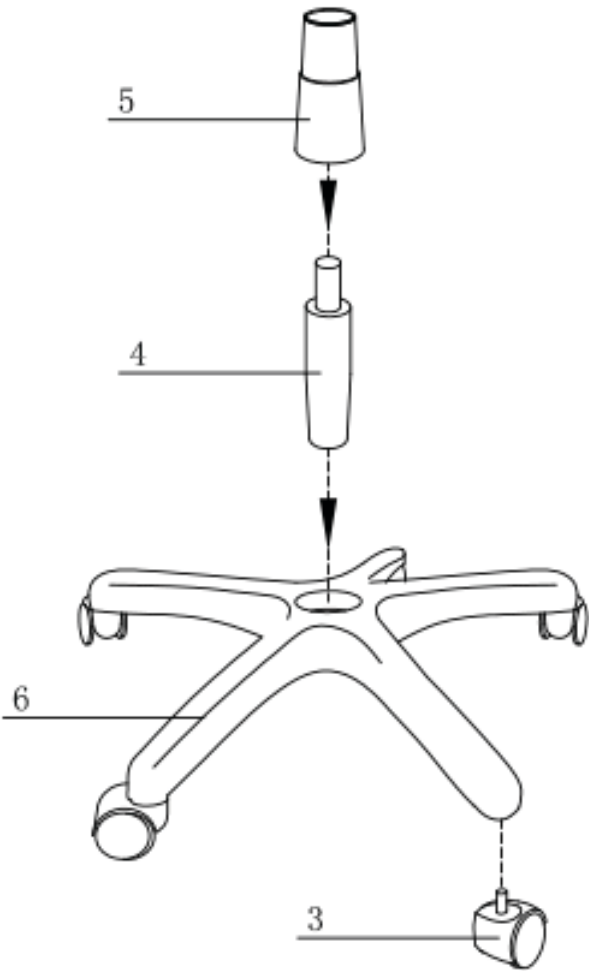

Step 1.

- Screw the castors into the five-star base
- Insert gas lift into the base with castors
- Place the Set over the gas lift and press down

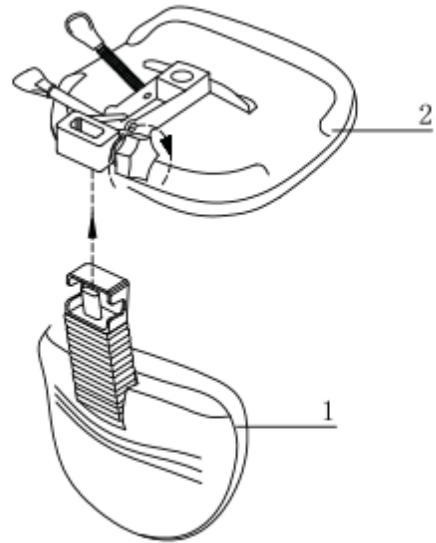

Step 2.

- Loosen knob on the seat, side the backrest into the back slot and tighten to desired height

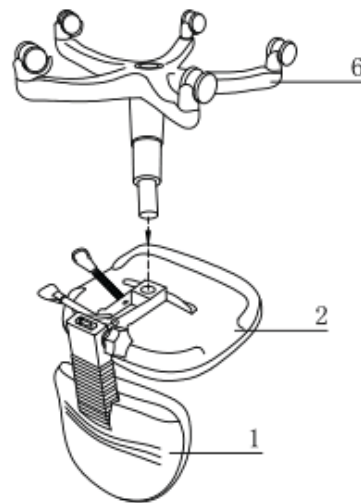

Step 3.

- Slot the seat onto the gaslift and tighten