

ASSEMBLY INSTRUCTIONS:

Product Code : GRAND-MOD-RC

Product Name: Grand Modello Reception Counter



TIME REQUIRED:

40 minutes

TOOLS REQUIRED:

Screwdriver, Electric Drill, Pencil, Measuring tape/Ruler *Tools are not included.

SKILL REQUIRED:

Easy ●●●●○ Hard

The Assembly Skill Rating is a 5-point system that shows the degree of effort needed in assembling a specific product. With 1 being easy for the average person and 5 requiring an expert. For most products, two persons are recommended.

NOTE

- As this is a commercial product, some intermediate skills may be required.
 - No pre-drill holes or markings are provided on our table or desk tops.
 - Please check you have all hardware before assembling.
- If you are missing any hardware, please contact your Danny reseller. Please ensure you have the name of the item, required hardware part and quantity.
 - Please retain your receipt as proof of purchase to validate your warranty.
- Assemble on a clean, flat, smooth surface such as a rug or carpet to avoid parts from being scratched.
 - Remove all wrapping materials, including staples and packing straps before you start to assemble
 - Keep all hardware parts out of reach of children.

CAUTION

- Heavy product. Do not attempt to lift or move without help
- Do not tighten screws and bolts until completely assembled.
- Do not use this product unless all bolts and screws are firmly secured and tightened.

WARNING

- If parts are missing, broken, damaged or worn stop using the product until all repairs are made.
 - Failure to follow these warnings could result in serious injury.



Assembly Instructions

MODEL NO: GRAND-MOD-RC

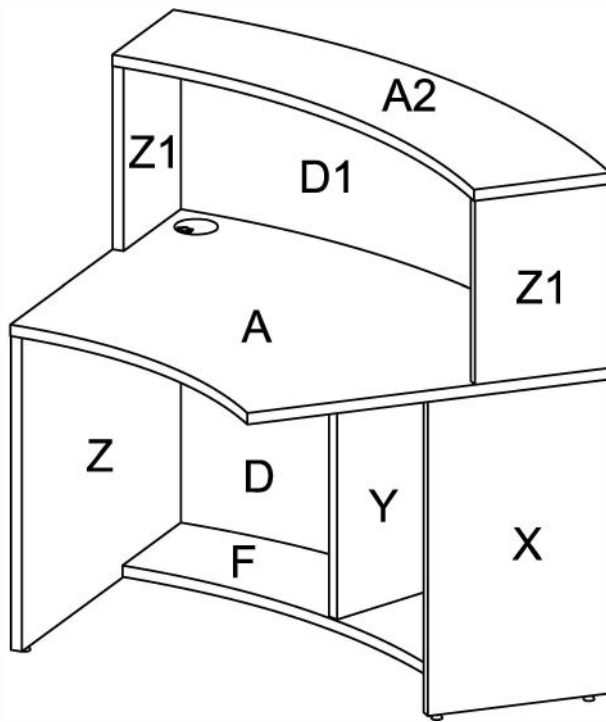

pin	6×35
	1
	20PCS
CAM	
	2
	22PCS
Cam Cover	
	3
	28PCS
ADJ.FEET	∅24×12H
	4
	4PCS
CONNECTOR	200×60
	5
	1PCS
Screw	6×12
	6
	8PCS
The back bracket	
	7
	12PCS

AU

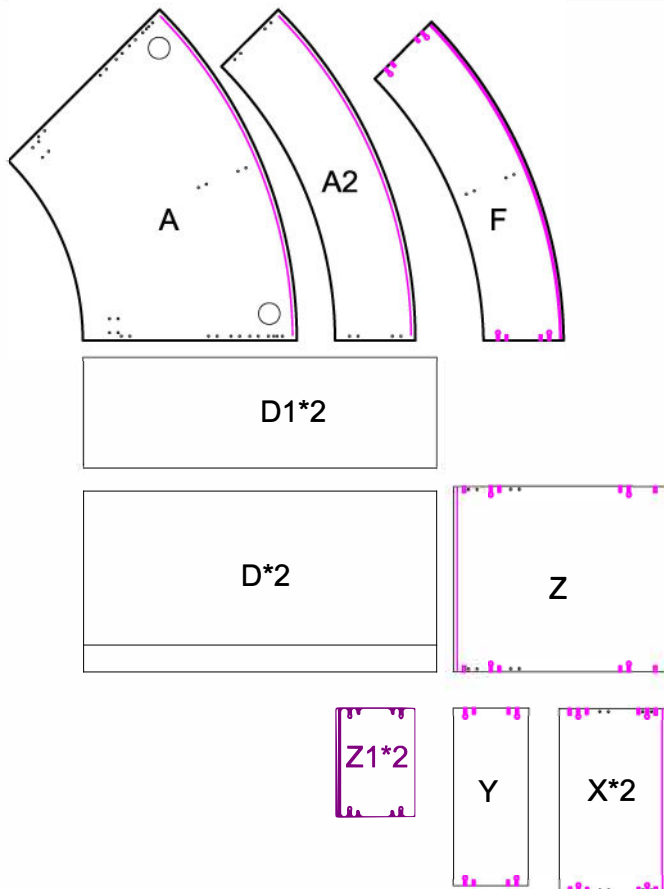

STEP 1

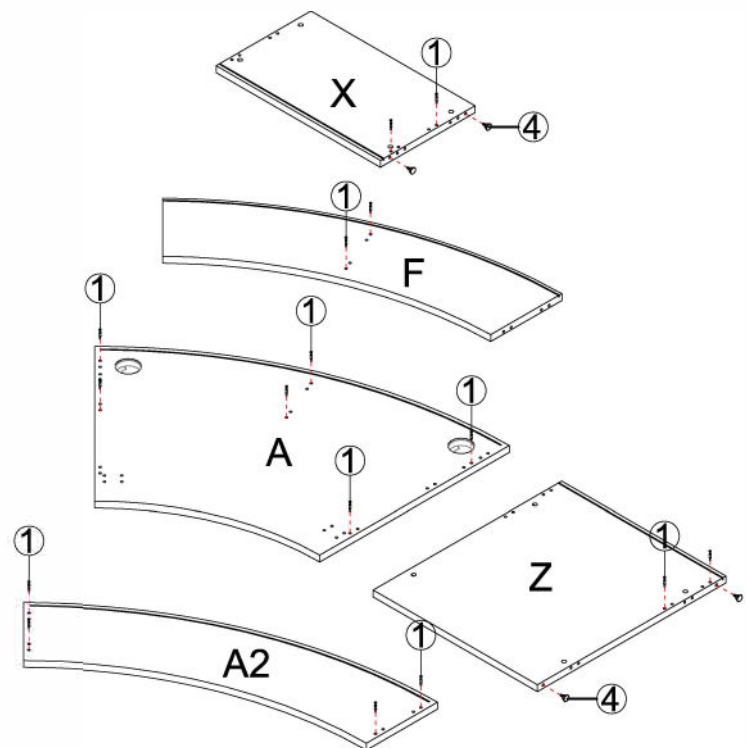

IMPORTANT NOTE:

- Place all laminated parts on a clean and smooth surface such as a rug or carpet to avoid the parts from being scratched.
- Check to be sure that you have all parts and hardware.
- Remove all wrapping materials, including staples & packing straps before you start to assemble.
- Don't tighten all screws/bolts until all completely assembled.
- Keep all hardware parts out of reach of children

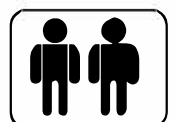

STEP2

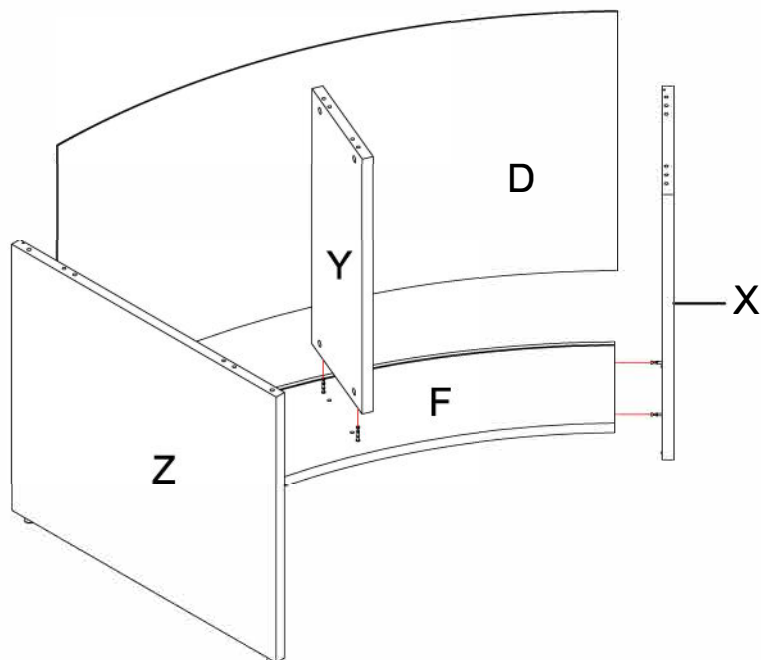

STEP3

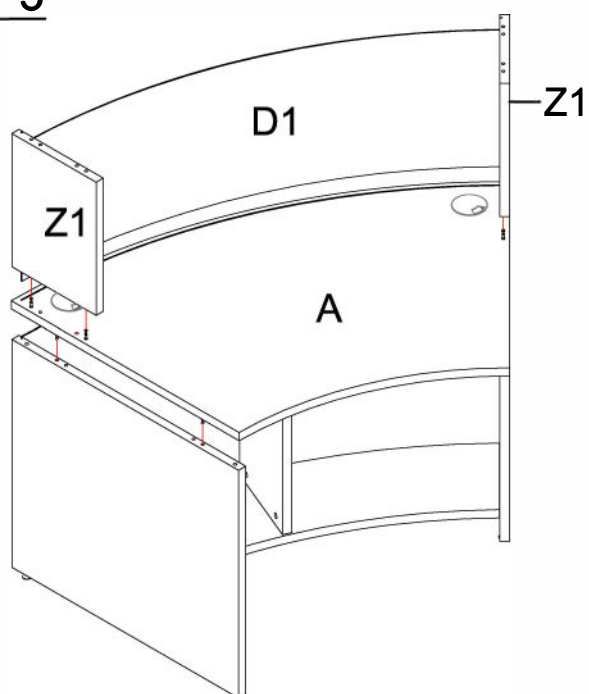

STEP4

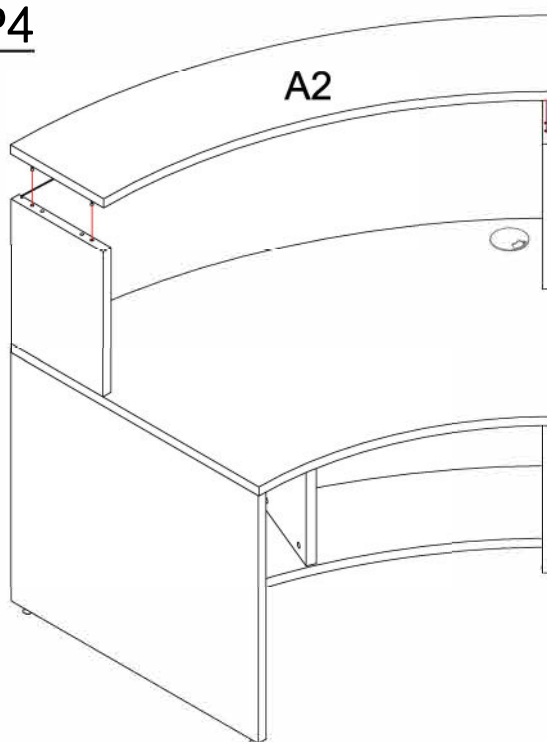

X and Z can be changed freely

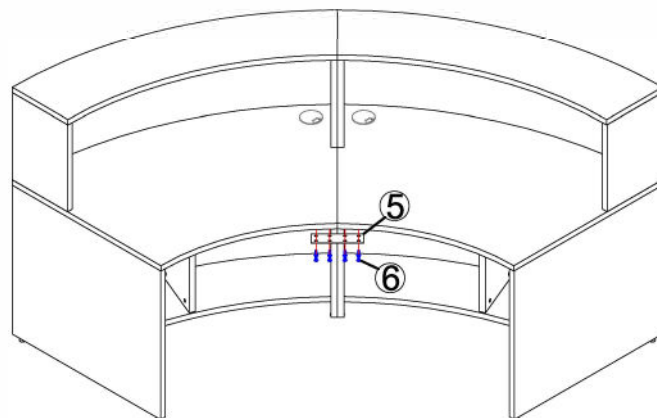
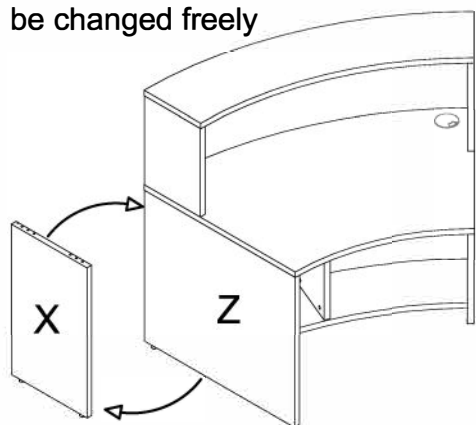

IMPORTANT NOTE:

- Place all laminated parts on a clean and smooth surface such as a rug or carpet to avoid the parts from being scratched.
- Check to be sure that you have all parts and hardware.
- Remove all wrapping materials, including staples & packing straps before you start to assemble.
- Don't tighten all screws/bolts until all completely assembled.
- Keep all hardware parts out of reach of children



Assembly Instructions

MODEL NO.: GRAND-MOD-RC

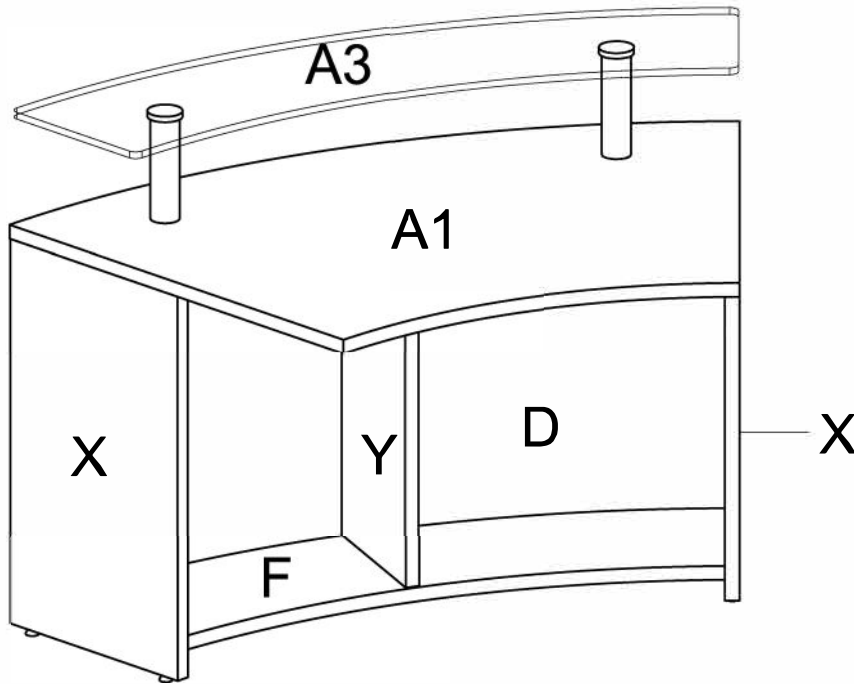

AU

pin 6×35	1	12PCS
CAM	2	14PCS
Cam Cover	3	20PCS
ADJ.FEET #24×12H	4	4PCS
CONNECTOR 200×60	5	1PCS
Screw 6×12	6	8PCS
The back bracket	7	6PCS
glass top support #50×193H	8	2PCS

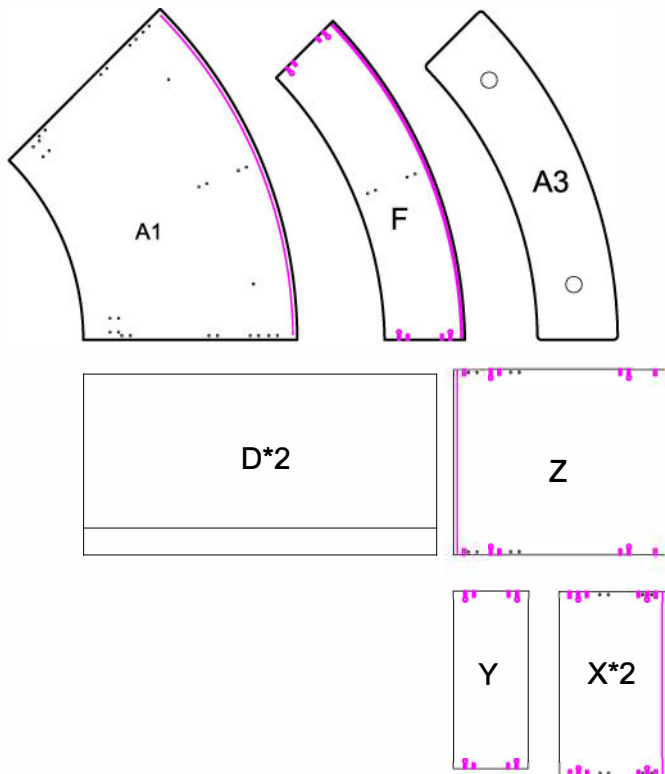

STEP1

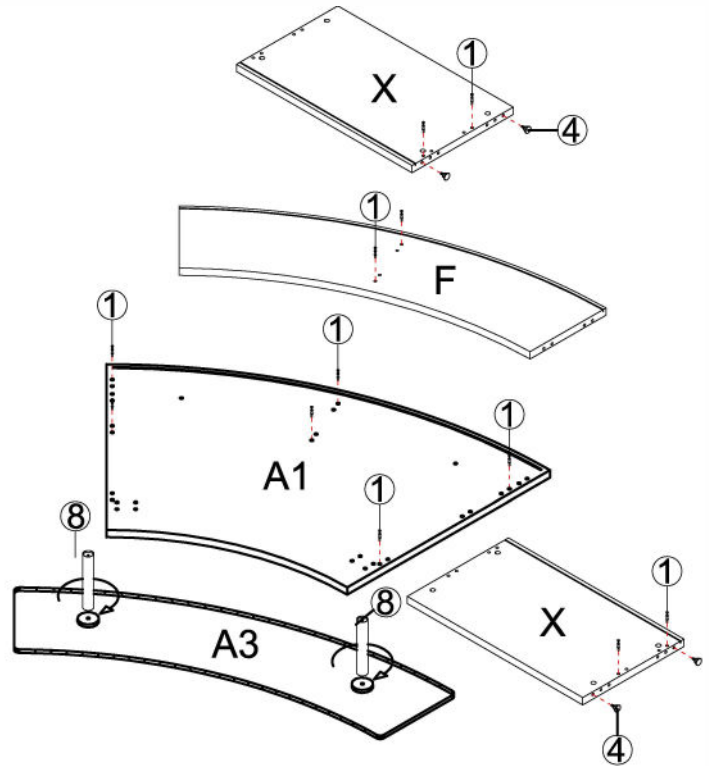

IMPORTANT NOTE:

- Place all laminated parts on a clean and smooth surface such as a rug or carpet to avoid the parts from being scratched.
- Check to be sure that you have all parts and hardware.
- Remove all wrapping materials, including staples & packing straps before you start to assemble.
- Don't tighten all screws/bolts until all completely assembled.
- Keep all hardware parts out of reach of children

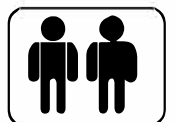

STEP 2

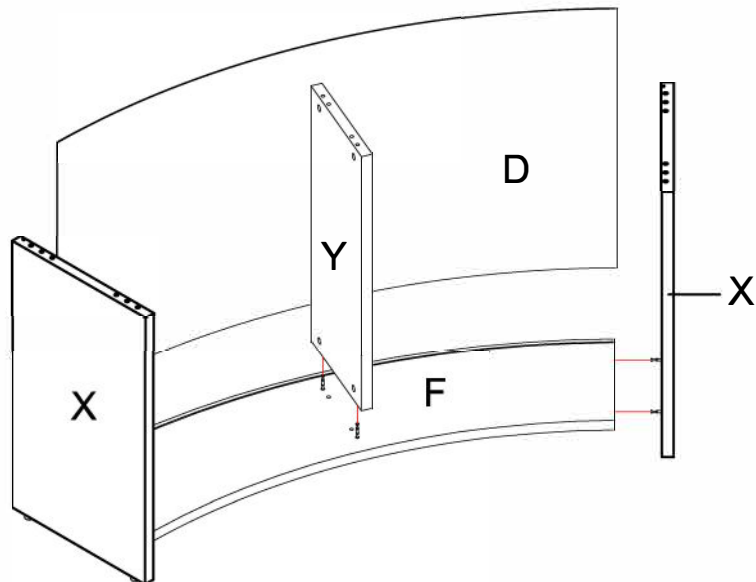

STEP 3

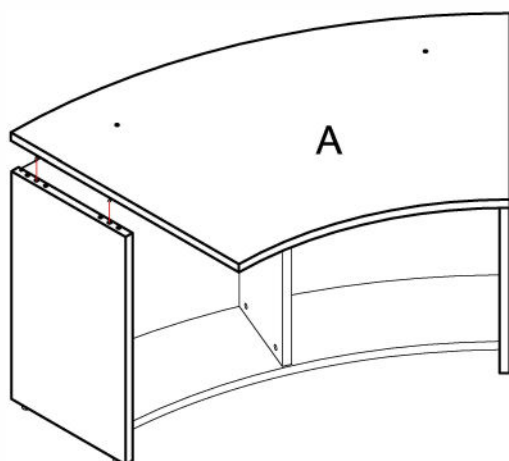

STEP 4

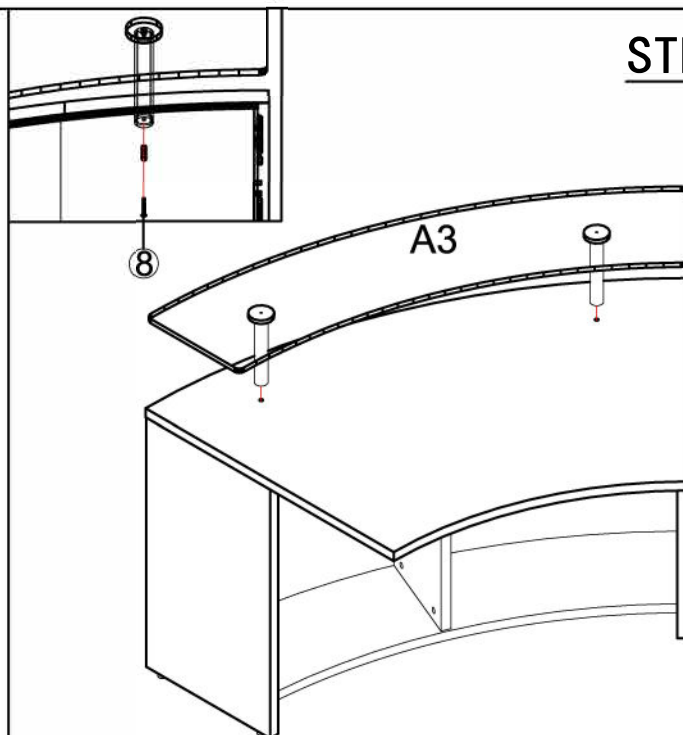

X and Z can be changed freely

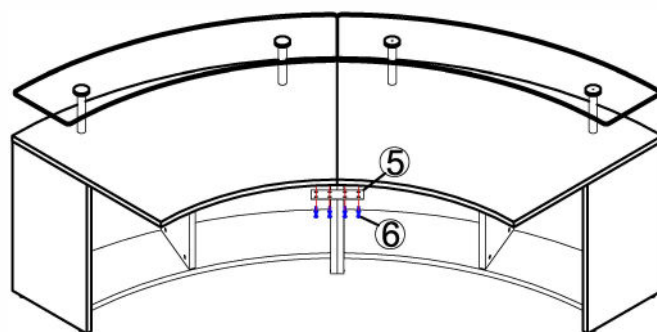
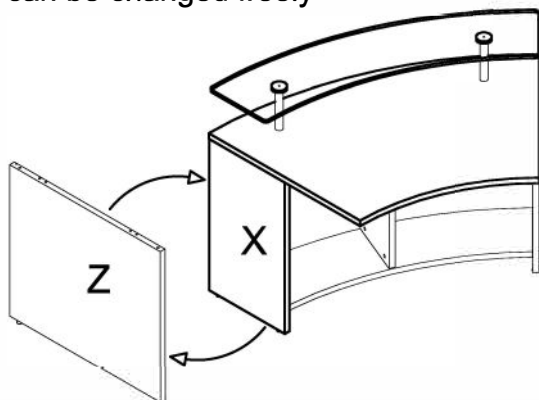

IMPORTANT NOTE:

- Place all laminated parts on a clean and smooth surface such as a rug or carpet to avoid the parts from being scratched.
- Check to be sure that you have all parts and hardware.
- Remove all wrapping materials, including staples & packing straps before you start to assemble.
- Don't tighten all screws/bolts until all completely assembled.
- Keep all hardware parts out of reach of children

